

Laadks

TWA 800A/DBT



Flat wagon unit with extreme low floor and scotch blocks
 Stark abgesenkte Flachwagen-einheit mit Radvorlegern

	A	B*	C*	
S	39,5 t	47,5 t	47,5 t	**
120	00,0 t			

* The respective country approvals must be observed.
 Die jeweiligen Länderzulassungen sind zu beachten.

Gauge Profil	G1
Type of brake block LL-brake block Sohlenart LL-Sohle (low noise, low friction)	LL
Overall length over buffers Wagenlänge über Puffer	27.000 mm
Loading length Ladelänge	25.760 mm
Loading length horizontally Ladelänge horizontal	18.870 mm
Loading width Ladebreite	3.110 mm
Number of scotch blocks Anzahl Radvorleger	32 units
Tare weight Eigengewicht	ca. 24.500 kg

Maximum floor pressure allowed Zulässige Fußbodenbelastung	50 kN
Floor height above top of rail Fußbodenhöhe über Schienenoberkante	800 mm
Minimum curve radius Kleinster befahrbarer Gleisbogenhalbmesser	75 m
Guardrail Absturzsicherung	no

Extra information per half wagon

Zusatzdaten je Wagenhälfte

Number of scotch blocks (retractable) Anzahl Radvorleger (versenkbar)	16 units
Securing rings (lowered in the middle of wagon) Ösen (versenkt in Wagenmitte)	12 units
Load capacity Tragfähigkeit	ca. 23,75 t

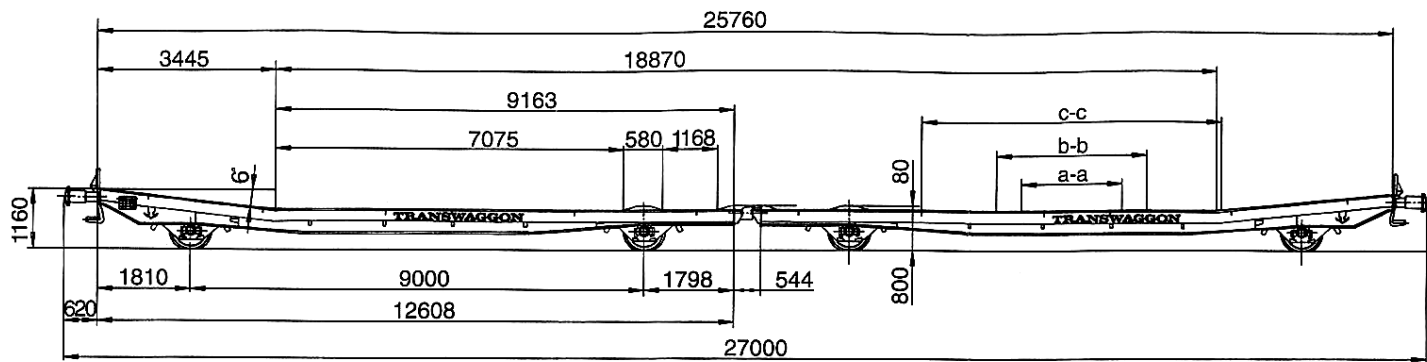

	m	t	▲▲
a-a	2	15,0	17,0
b-b	3	16,0	20,0
c-c	7	22,0	23,5

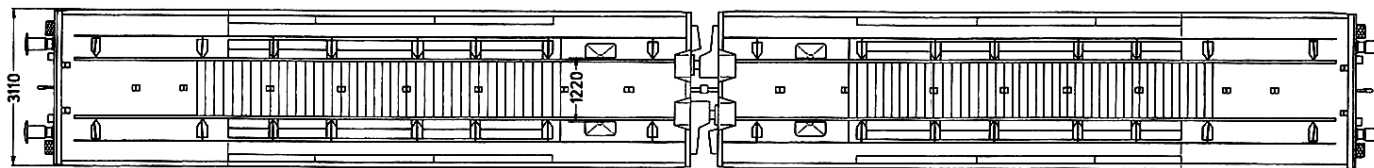

Rail to fix wedges
Lochschiene
Check rail for wedges
Führungsschiene
Rail to fix wedges
Lochschiene

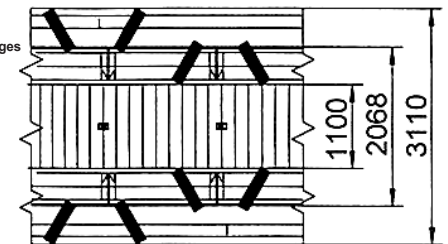

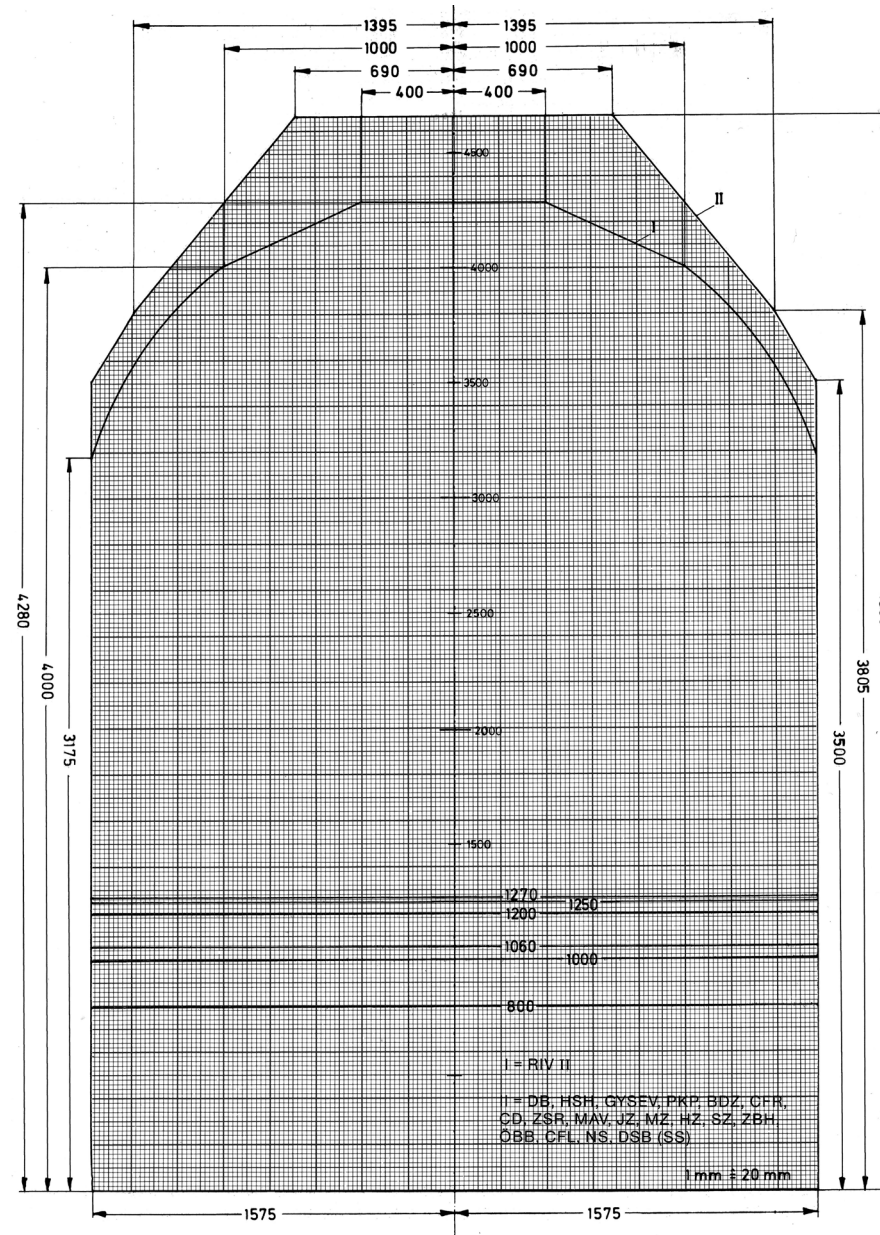

Stand Mai 2003